

**WATER TAXI II
GOLD COAST 39WP
GUEST SHUTTLE**

DESIGN BRIEF

In the beginning, there was an idea...

In 1992, one year after building the successful GC39WP wave-piercer prototype, *Water Taxi II* became the basis for the designs of the next twelve world-famous GCY wave-piercers. She and several sisters are still operating between the US and British Virgin Islands amazing boaters as they zoom past effortlessly slicing through the chop.



SPECIFICATIONS

LOA	39'
BOA	14'
Draft	1'3"
Light Displacement	7,000 lbs
Heavy Displacement	11,000 lbs
Passengers	20
Engines	2 x 125 hp
Fuel Capacity	2 x 50 gal
Cruise Speed	22 knots
Full Speed	26 knots

MORE PICTURES AND DRAWINGS BELOW.

GOLD COAST YACHTS®

ST CROIX, U.S. VIRGIN ISLANDS



GOLD COAST YACHTS®

ST CROIX, U.S. VIRGIN ISLANDS



GOLD COAST YACHTS®

ST CROIX, U.S. VIRGIN ISLANDS

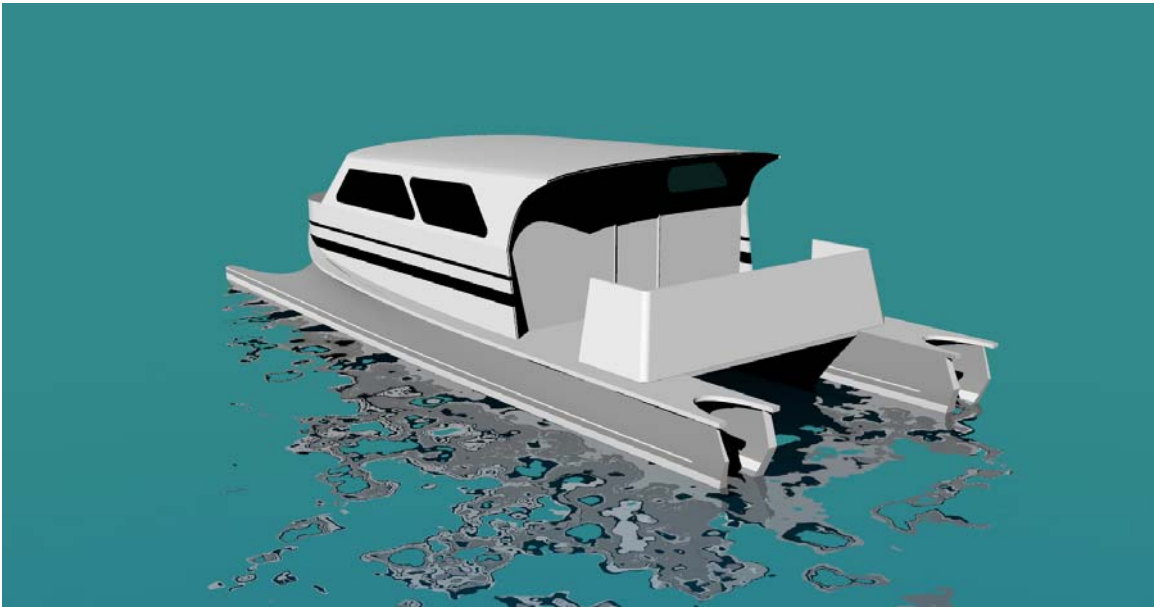
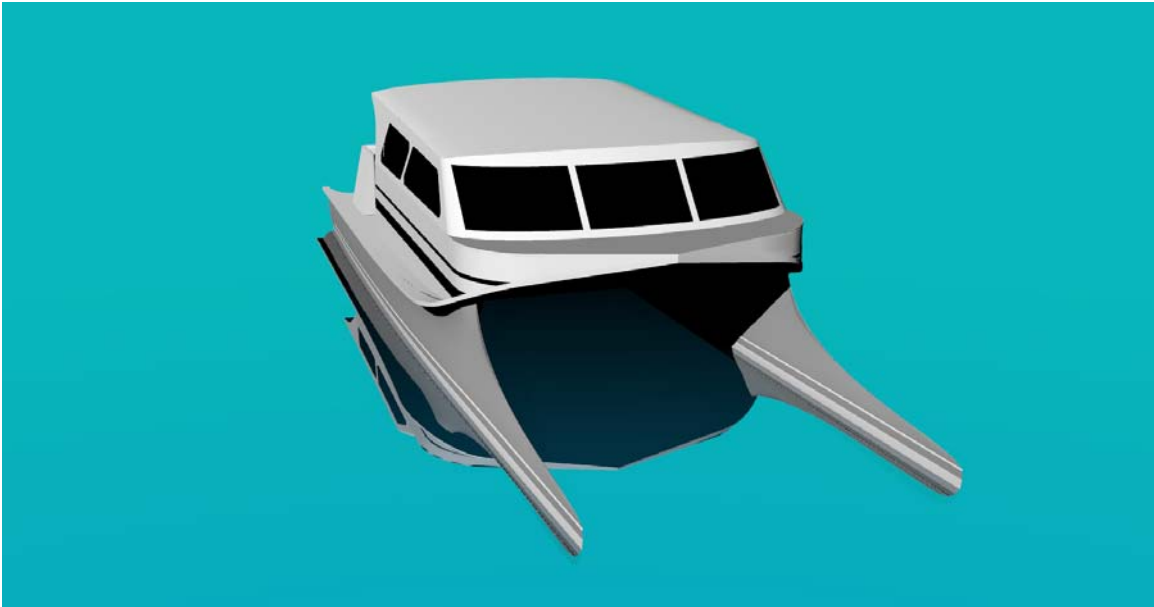

GOLD COAST YACHTS®

ST CROIX, U.S. VIRGIN ISLANDS



GOLD COAST YACHTS®

ST CROIX, U.S. VIRGIN ISLANDS

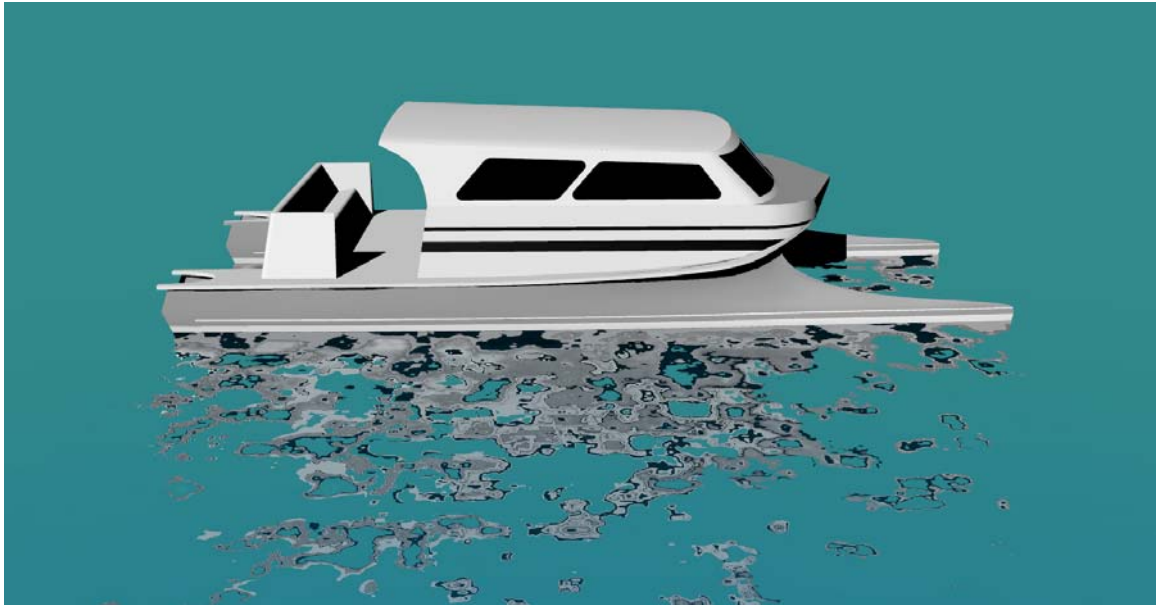

GOLD COAST YACHTS®

ST CROIX, U.S. VIRGIN ISLANDS



GOLD COAST YACHTS®

ST CROIX, U.S. VIRGIN ISLANDS



Scale: 3/16"=1'

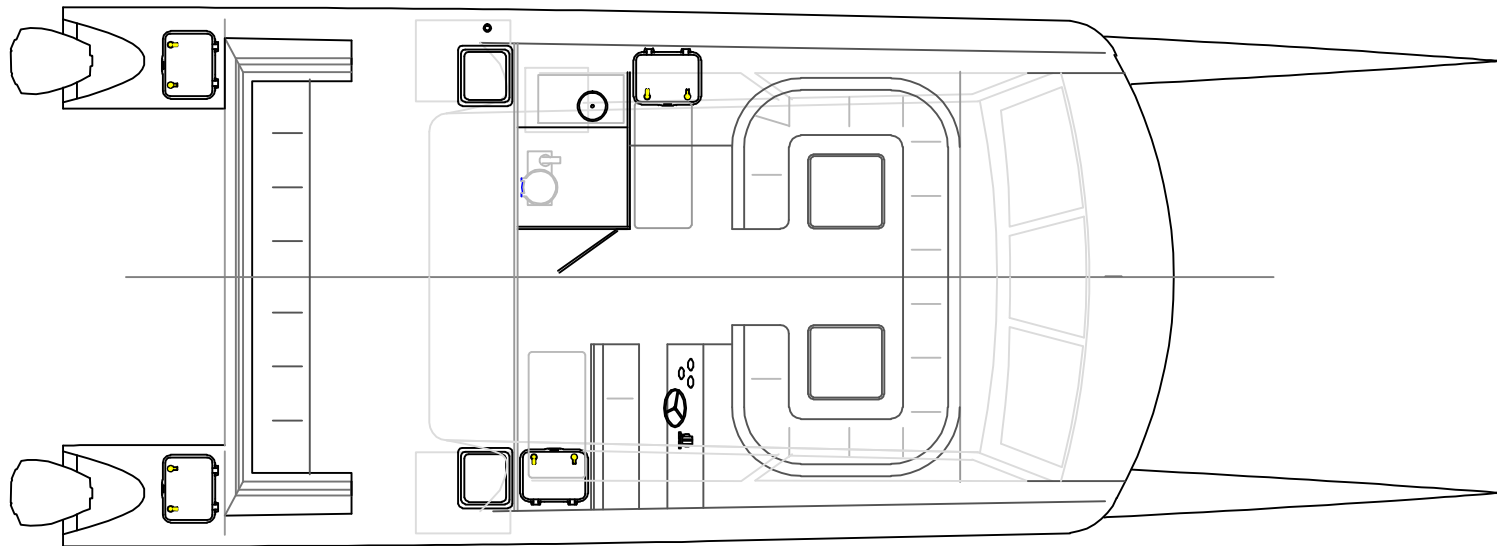
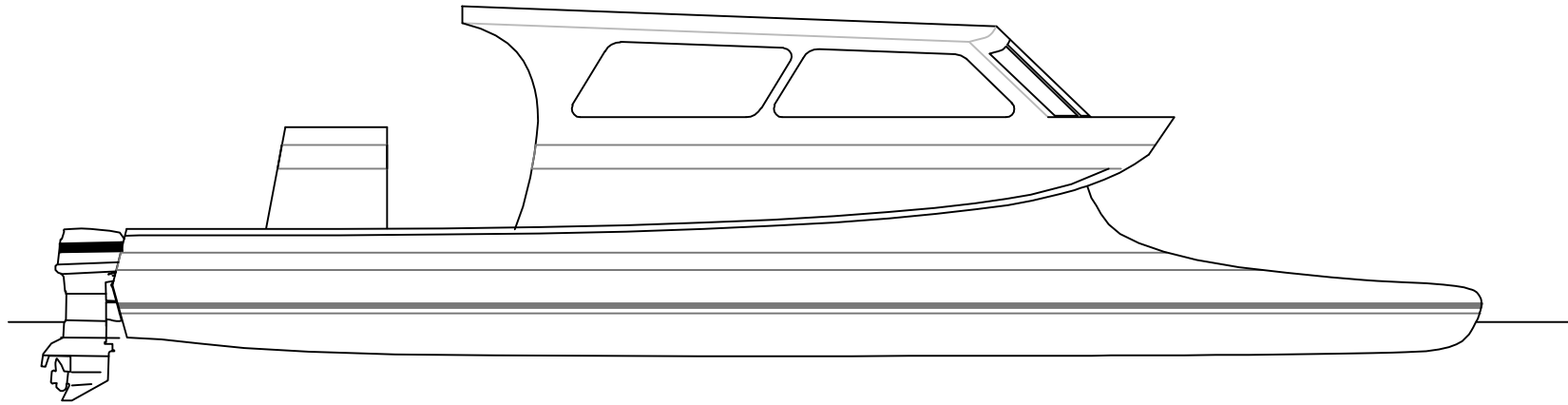

GC40WP
GOLD COAST YACHTS

