

GOLD COAST 54P SNORKEL BOAT CONCEPTUAL DESIGN

SPECIFICATIONS

LOA	55'
BOA	20'
Light Displacement	17,800 lbs
Heavy Displacement	30,000 lbs
Passengers	49
Engines	2 X 305 hp
Fuel Capacity	2 X 100 gal.
Cruise Speed	22 knots
Full Speed	27 knots

SCALE DRAWINGS BELOW.

Scale: 1/8"=1'

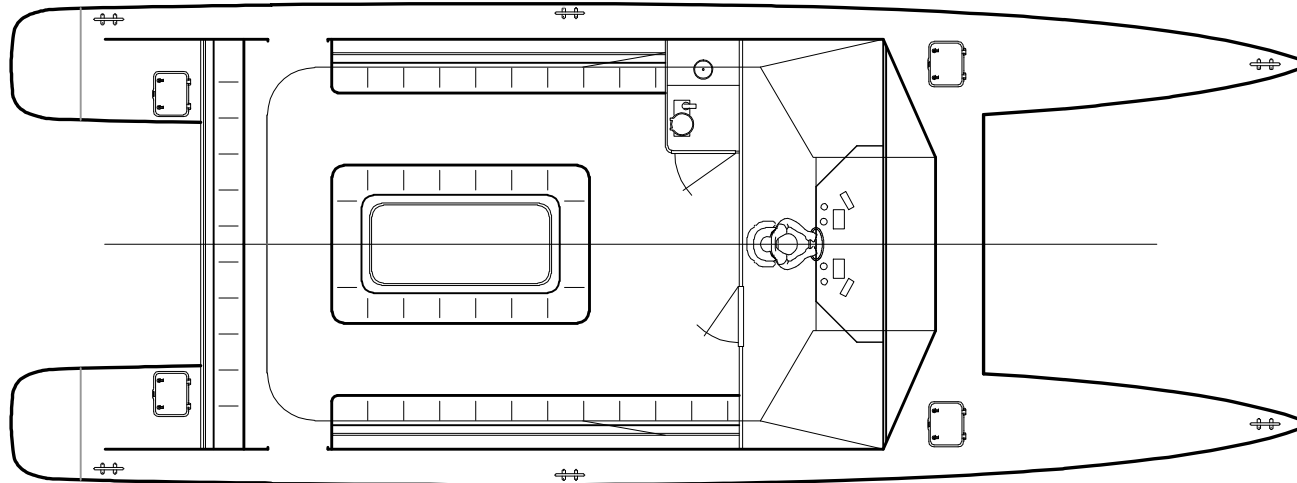
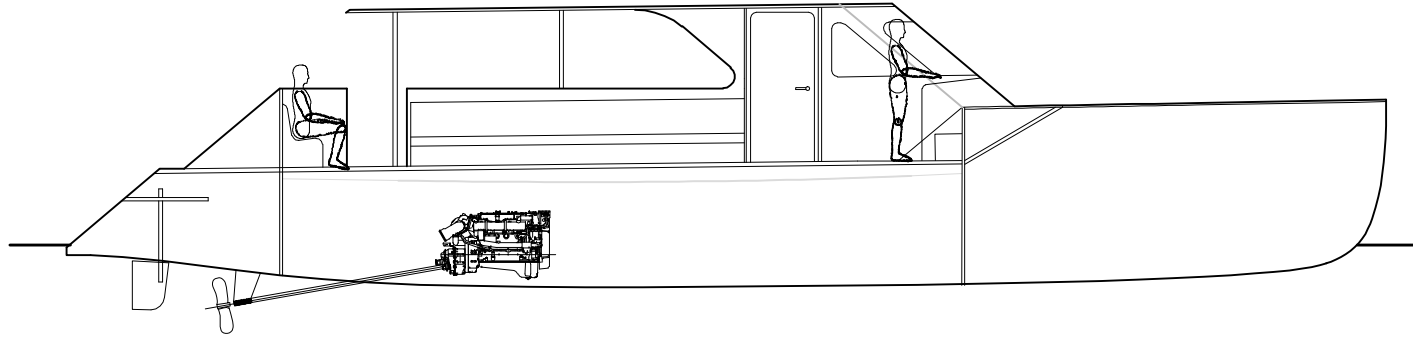

GC54P
GOLD COAST YACHTS

Scale: 1/8"=1'

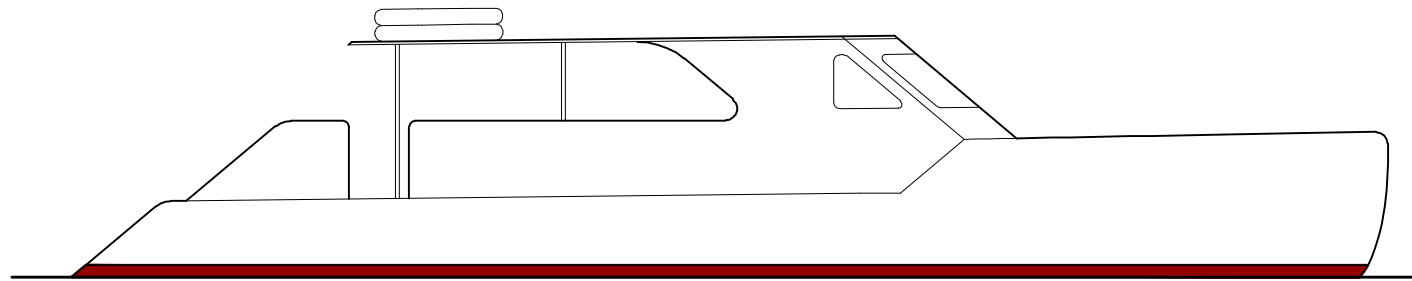

GC54P
GOLD COAST YACHTS